



TORNATECH

Project: _____

Customer: _____

Engineer: _____

Pump Manufacturer: _____

**Technical Data
Submittal Document**

Model GPL+GLU

Limited Service Full Service
Across the Line Start
Electric Fire Pump Controller
with Automatic Power Transfer Switch

Contents:

Data Sheets
Dimensional Data
Wiring Schematics
Field Connections

Note: The drawings included in this package are for controllers covered under our standard offering. Actual AS BUILT drawings may differ from what is shown in this package.



**N.Y.C.
APPROVED**



May 2024

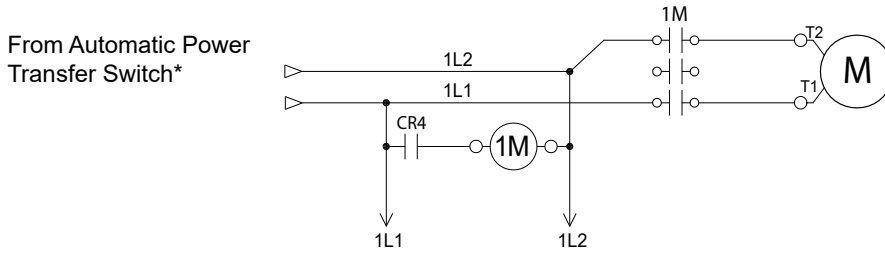

Standard, Listings, Approvals and Certifications	Built to NFPA 20 (latest edition)	
	Underwriters Laboratory (UL)	<ul style="list-style-type: none"> • UL218 - Fire Pump Controllers • UL 1008 - Automatic power transfer switches for fire pump controllers
	New York City	Accepted for use in the City of New York by the Department of Buildings
	Optional	
	CE Mark	Various EN, IEC & CEE directives and standards
Enclosure	Protection Rating Standard: NEMA 2 Optional NEMA 12 NEMA 4X-304 sst painted NEMA 3 NEMA 4X-304 sst brushed finish NEMA 3R NEMA 4X-316 sst painted NEMA 4 NEMA 4X-316 sst brushed finish	
	Accessories <ul style="list-style-type: none"> • Bottom entry gland plate • Lifting Lugs • Keylock handle 	Paint Specifications <ul style="list-style-type: none"> • Red RAL3002 • Powder coating • Glossy textured finish

Shortcircuit Withstand Rating	120V to 240V - 1ph - 60Hz	
	Normal Power	Alternate Power
Standard	100,000A	

*Please see Disconnecting Means details on page 3



Limitations	<ul style="list-style-type: none"> • Across the line starting only • Horsepower rating of maximum 30hp • Can only be installed where acceptable by the authority having jurisdiction • Not accepted in FM insured property
Ambient Temperature Rating	<p>Standard: 4°C to 40°C / 39°F to 104°F</p> <p>Optional: 4°C to 55°C / 39°F to 131°F</p> <p>Controllers built in Dubai, UAE (Tornatech FZE) are supplied standard with 55°C rating.</p>
Surge Suppression	Surge arrestor rated to suppress surges above line voltage
Disconnecting Means	<ul style="list-style-type: none"> • Door interlocked in the ON position • Circuit breaker continuous rating not less than 115% of motor full load current • Overcurrent sensing non-thermal type, magnetic only • Instantaneous trip setting of not more than 20 times the motor full load current • Common flange mounted operating handle
Service Entrance Rating	Suitable as service entrance equipment
Emergency Start Handle	<ul style="list-style-type: none"> • Flange mounted • Pull and latch activation • Integrated limit switch • Across the line start (direct on line)
Locked Rotor Protector	<ul style="list-style-type: none"> • Operate shunt trip to open circuit breaker • Factory set at 600% of motor full load current • Trip between 8 and 20 seconds
Electrical Readings	<ul style="list-style-type: none"> • Voltage phase to phase (normal power) • Amperage of each phase when motor is running
Pressure Readings	<ul style="list-style-type: none"> • Continuous system pressure display • Cut-in and Cut-out pressure settings
Pressure and Event recorder	<ul style="list-style-type: none"> • Pressure readings with date stamp • Event recording with date stamp • Under regular maintained operation, events are stored in memory for the life of the controller. • Data viewable on operator interface display screen • Downloadable by USB port to external memory device
Pressure Sensing	<ul style="list-style-type: none"> • Pressure transducer and run test solenoid valve assembly for fresh water application • Pressure sensing line connection 1/2" Female NPT • Drain connection 3/8" • Rated for 0-500PSI working pressure (standard display at 0-300PSI) • Externally mounted with protective cover



Audible Alarm	Alarm buzzer - 85 dB at 10ft. (3m)
Visual Indications	<ul style="list-style-type: none"> • Power available • Motor run • Periodic test • Manual start • Deluge valve start • Remote automatic start • Remote manual start • Emergency start • Pump on demand/Automatic start • Pump room temperature (°F or °C) • Lockout
Visual & Audible Alarms	<p>Visual only</p> <ul style="list-style-type: none"> • Alternate lock rotor current • Alternate power phase reversal • Automatic transfer switch trouble • Control voltage not healthy • Invalid cut-in • Lock rotor current • Loss of power • Low ambient temperature • Low water level • Motor trouble • Normal power phase reversal • Overcurrent • Overvoltage • Phase loss L1 • Phase loss L2 • Phase loss L3 • Phase unbalanced • Pressure transducer fault detected • Pump on demand • Pump room alarm • Service required • Undercurrent • Undervoltage • Check weekly test solenoid • Weekly test cut-in reached <p>Visual and Audible</p> <ul style="list-style-type: none"> • ACB in OFF or tripped • Alternate IS tripped/open • Fail to start
Remote Alarm Contacts	<p>DPDT-8A-250V.AC</p> <ul style="list-style-type: none"> • Power available • Phase reversal • Motor run • Common pump room alarm (field re-assignable)** <ul style="list-style-type: none"> • Overvoltage • Undervoltage • Phase unbalance • Low pump room temperature • High Pump room temperature • Common motor trouble (field re-assignable)** <ul style="list-style-type: none"> • Overcurrent • Fail to start • Undercurrent • Ground fault • Free (field programmable)**

**Tornatech reserves the right to use any of these three alarm points for special specific application requirements.



ViZiTouch V2.1 Operator Interface	<ul style="list-style-type: none"> • Embedded microcomputer with software PLC logic • 7.0" color touch screen (HMI technology) • Upgradable software • Multi-language 			
Communication Protocol Capability	<ul style="list-style-type: none"> • Protocol: Modbus • Connection type: Shielded female connector RJ45 • Frame Format: TCP/IP • Addresses: See bulletin MOD-GPx 			
Operation	Automatic Start	<ul style="list-style-type: none"> • Start on pressure drop • Remote start signal from automatic device • Deluge valve start 		
	Manual Start	<ul style="list-style-type: none"> • Start pushbutton • Run test pushbutton • Remote start from manual device 		
	Stopping	<ul style="list-style-type: none"> • Manual with Stop pushbutton • Automatic after expiration of minimum run timer *** 		
	Timers	Field Adjustable & Visual Countdown	<ul style="list-style-type: none"> • Minimum run timer ***(off delay) • Sequential start timer (on delay) • Periodic test timer 	
	Actuation	Visual Indication	<ul style="list-style-type: none"> • Pressure • Non-pressure 	
	Mode		<ul style="list-style-type: none"> • Automatic • Non-automatic 	

***Can only be used if approved by the AHJ



Automatic Power Transfer Switch	Surge Suppression	Surge arrestor rated to suppress surges above line voltage
	Disconnecting Means	<ul style="list-style-type: none"> - Door interlocked in the ON position - Circuit breaker continuous rating not less than 115% of motor full load current - Overcurrent sensing non-thermal type, magnetic only - Instantaneous trip setting of not more than 20 times the motor full load current - Common flange mounted operating handle
	Locked Rotor Protector	<ul style="list-style-type: none"> • Operate shunt trip to open circuit breaker • Factory set at 600% of motor full load current • Trip between 8 and 20 seconds
	Visual Indications	<ul style="list-style-type: none"> • Alternate (emergency) isolating switch in the OFF position • Alternate (emergency) voltage phase to phase • Transfer switch in normal position • Transition timers
	Visual Alarms	<ul style="list-style-type: none"> • Transfer switch trouble • Alternate power phase reversal • Alternate isolating switch open/tripped • Alternate circuit breaker open/tripped • Alternate side locked rotor current
	Transfer switch test pushbutton	
	Bypass for re-transfer and generator shutdown	
	Electrically operated and mechanically held in the normal or alternate position	
	Provision for manual operation	
	Remote Alarm Contacts SPDT-8A-250VAC <ul style="list-style-type: none"> • Isolating switch in the OFF position • Transfer switch in normal position • Transfer switch in alternate (emergency) position 	
	Time Delays <ul style="list-style-type: none"> • Momentary normal power outage override (factory set at 3 sec - field adjustable 1 to 3 sec) • Alternate (emergency) power available delay (factory set at 3 sec - field adjustable 1 to 3 sec) • Transfer trouble delay (factory set at 20 sec - field adjustable 1 to 60 sec) • Retransfer to normal (factory set at 5 min - field adjustable 1 to 20 min) • Generator cooldown (factory set at 5 min - field adjustable 1 to 20 min) 	
	Voltage Sensing <ul style="list-style-type: none"> • Transfer to alternate (normal power dropout) 85% of nominal - field adjustable 0 to 100% • Phase reversal transfer to alternate • Retransfer to normal (normal power pickup) 90% of nominal - field adjustable 0 to 100% 	
	Audible Alarm (AIS Open) Alarm buzzer - 85 dB at 10ft. (3m)	
	Generator Start Connection SPDT-8A-250V.AC	



Model GPL+GLU Electric Fire Pump Controller with Automatic Power Transfer Switch

A4	Flow switch provision	C18	High water reservoir level c/w visual indication and alarm contact (DPDT)
A8	Foam pump application w/o pressure transducer and run test solenoid valve.	C19	Emergency start alarm contact (DPDT)
A9	Low zone pump control function	C20	Manual start alarm contact (DPDT)
A10	Middle zone pump control function	C21	Deluge valve start alarm contact (DPDT)
A11	High zone pump control function	C22	Remote automatic start alarm contact (DPDT)
A13	Non-pressure actuated controller w/o pressure transducer and run test solenoid valve	C23	Remote manual start alarm contact (DPDT)
A16	Lockout/interlock circuit from equipment installed inside the pump room	C24	High pump room temperature alarm contact (DPDT)
B11	Built in alarm panel (120V.AC supervisory power) providing indication for: • Audible alarm & silence pushbutton for motor run, phase reversal, loss of phase. • Pilot lights for loss of phase & supervisory power available	C25	Second set of standard alarm contacts (DPDT) (Typical for city of Los Angeles and Denver)
B11B	Built in alarm panel same as B11 but 220-240VAC supervisory power	Cx	Additional visual and alarm contact (Specify function) (DPDT)
B19A	High motor temperature c/w thermostat relay and alarm contacts (DPDT)	D1	Low suction pressure transducer for fresh water rated at 0-300PSI with visual indication and alarm contact
B19B	High motor temperature c/w PT100 relay and alarm contacts (DPDT)	D1A	Low suction pressure transducer for sea water rated at 0-300PSI with visual indication and alarm contact
B21	Ground fault alarm detection c/w visual indication and alarm contact (DPDT)	D13A	High withstand rating for (normal power section) • 380v to 480v=65ka • 600v = 25ka
C1	Extra motor run alarm contact (DPDT)	D14	Anti-condensation heater & thermostat
C4	Periodic test alarm contact (DPDT)	D14A	Anti-condensation heater & humidistat
C6	Low discharge pressure alarm contact (DPDT)	D14B	Anti-condensation heater & thermostat & humidistat
C7	Low pump room temperature alarm contact (DPDT)	D15	Tropicalization
C10	Low water reservoir level alarm contact (DPDT)	D18	CE Mark with factory certificate
C11	High electric motor temperature alarm contact (DPDT)	D26	Modbus with RTU frame format and RS485 connection
C12	High electric motor vibration c/w visual indication and alarm contact (DPDT)	D27	Motor heater connection (external single phase power source and heater on/off contact)
C14	Pump on demand / automatic start alarm contact (DPDT)	D27A	Motor heater connection (internal single phase power source and heater on/off contact)
C15	Pump fail to start alarm contact (DPDT)	D28	Customized drawing set
C16	Control voltage healthy alarm contact (DPDT)	D34A	Field programmable I/O board - 5 Input / 5 output
C17	Flow meter valve loop open c/w visual indication and alarm contact (DPDT)	D36	Redundant pressure transducer for fresh water rated for 0-500PSI

Note: Options chosen from this page are not electrically represented on the wiring schematics in this submittal package.

Note: Options chosen from this page are not electrically represented on the wiring schematics in this submittal package.



D36A	Redundant pressure transducer for sea water rated for 0-500PSI
E1	Permanent load shedding contacts
E2	Temporary pump motor start period load shedding contacts
E3	Temporary & permanent load shedding contacts
F2	Anti condensation heater & thermostat (alternate power section)
F2A	Anti condensation heater & humidistat (alternate power section)
F2B	Anti condensation heater & thermostat & humidistat (alternate power section)
F6A	High withstand rating for (model GLU only) : 380v to 480v=65ka • 600v=25ka

L01	Other language and English (bilingual)
L02	French
L03	Spanish
L04	German
L05	Italian
L06	Polish
L07	Romanian
L08	Hungarian
L09	Slovakian
L10	Croatian
L11	Czech
L12	Portuguese
L13	Dutch
L15	Turkish
L16	Swedish
L21	Danish
L25	Chinese
L28	Finnish
L29	Norwegian

Additional Options:

Note: Options chosen from this page are not electrically represented on the wiring schematics in this submittal package.

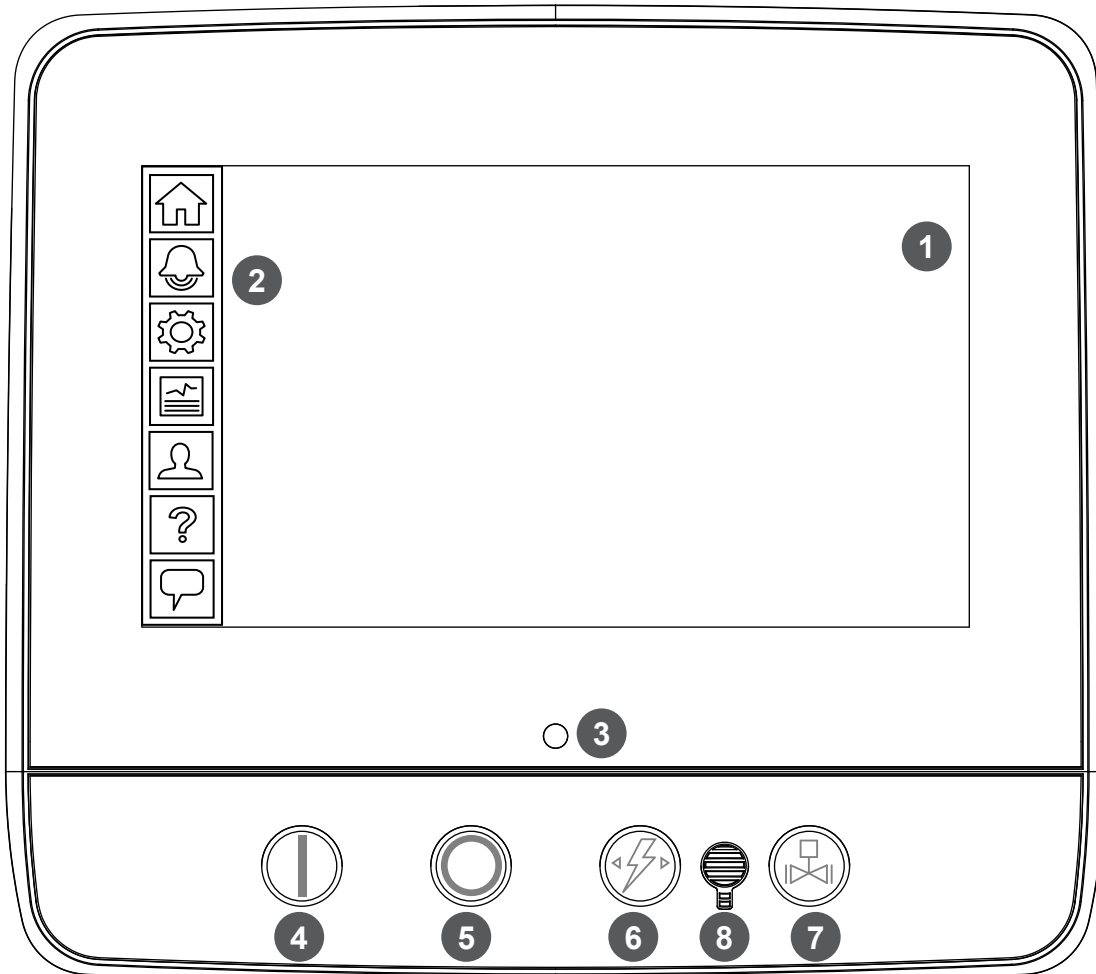

- | | |
|------------------------|---------------------------------|
| 1 - Color touch screen | 3 - Power LED (3 colors) |
| 2 - Onscreen menu | 4 - START button |
| • HOME page | 5 - STOP button |
| • ALARM page | 6 - TRANSFER SWITCH TEST button |
| • CONFIGURATION page | 7 - RUN TEST button |
| • HISTORY page | 8 - Alarm buzzer |
| • SERVICE page | |
| • MANUAL page | |
| • LANGUAGES page | |



© Tornatech, Inc. Not for construction.
Subject to change without notice.

	BY	DD/MM/YY
DRAWN BY	ACD	28/02/23
FINAL APPROVAL	FC	28/02/23

LIMITED SERVICE PUMP CONTROLLER WITH AUTOMATIC TRANSFER SWITCH

MODEL: GPL+GLU

BUILT TO THE LATEST EDITION OF THE NFPA20 & NFPA70



THIRD ANGLE
PROJECTION

DRAWING NUMBER
GPL-DI801/E
DWG REV. 0
SHEET 1 OF 1

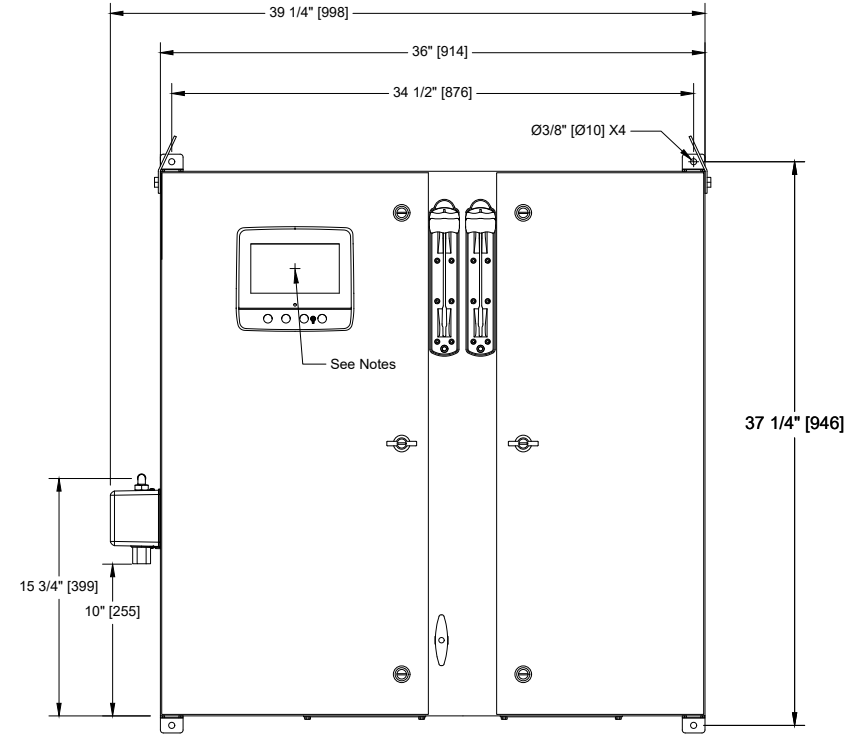
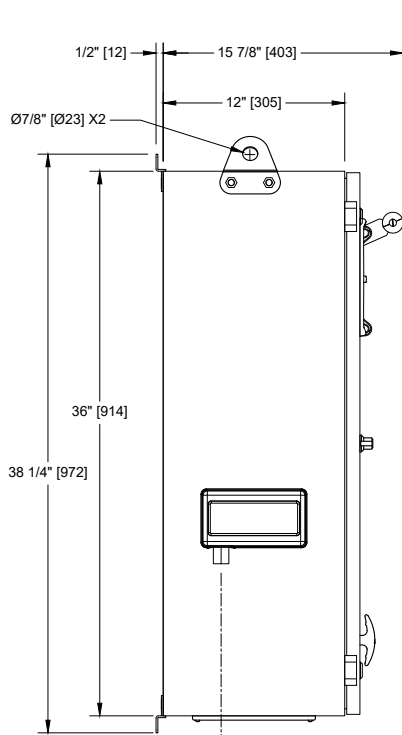

Voltage / Power Table		
Voltage	Min HP	Max HP
1 Phase		
110 - 120	1	7.5
208	3	15
220 - 240	3	15
3 Phases		
208	3	30
220 - 240	3	30
380 - 400 - 415	3	30
440 - 480	3	30
600	3	30

Sensing Line Connection - 1/2" F. NPT

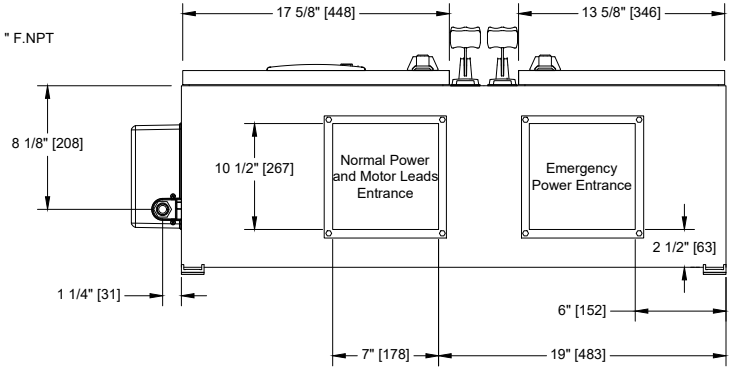

Notes:

- Standard NEMA: NEMA 2
- Standard paint : textured red RAL 3002.
- All dimensions are in inches [millimeters].
- Center of screen: 29-5/8" [751] from bottom (no feet).
- Bottom conduit entrance through removable gland plate recommended.
- Use watertight conduit and connector only.
- Protect equipment against drilling chips.
- Door swing equal to door width.



© Tornatech, Inc. Not for construction.
Subject to change without notice.

BY		DD/MM/YY
DRAWN BY	ACD	28/02/23
FINAL APPROVAL	FC	28/02/23

LIMITED SERVICE PUMP CONTROLLER ACROSS THE LINE / 1 PHASE WITH AUTOMATIC TRANSFER SWITCH

MODEL: GPL+GLU

BUILT TO THE LATEST EDITION OF THE NFPA20 & NFPA70



DRAWING NUMBER	GPL-WS810/E
DWG REV. 0	
SHEET 1 OF 2	

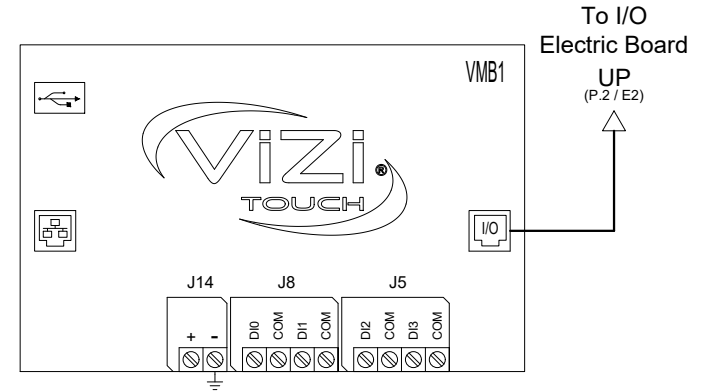
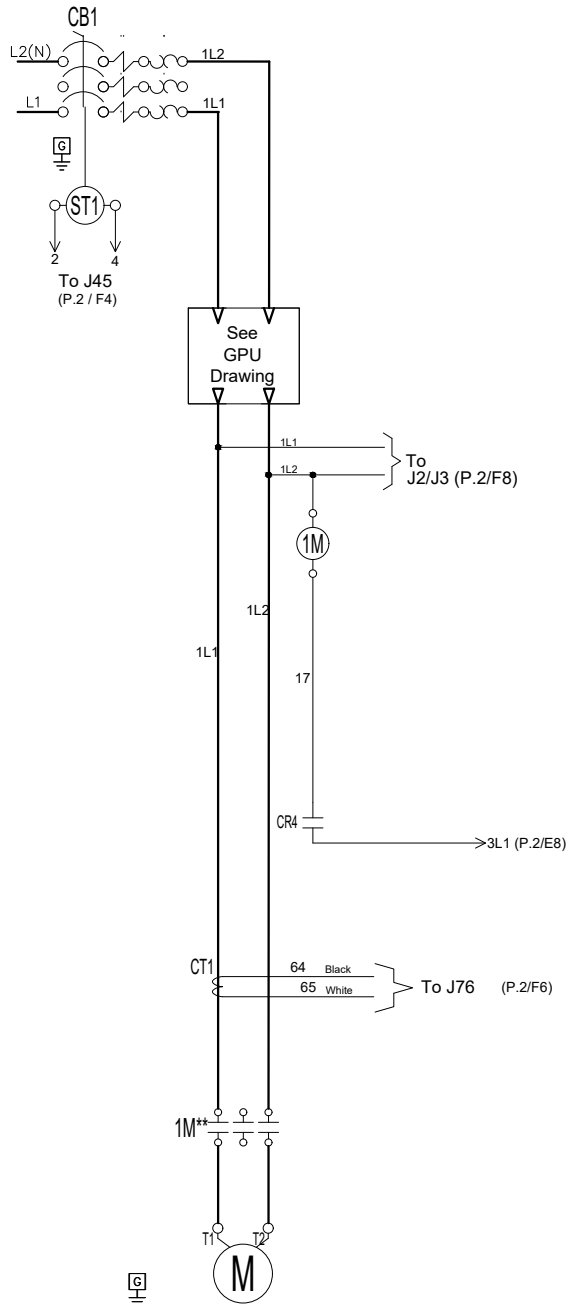

Legend	
1M	Contactor
AB	Alarm Bell
CB	Circuit Breaker
CR	Control Relay
CT	Current Transformer
EB	Electric I/O Board
J	Jumper
LS	Limit Switch
PT	Pressure Transducer
SA	Surge Arrester
ST	Shunt Trip
SV	Solenoid Valve
VMB	Main Board
XTR	Transformer



© Tornatech, Inc. Not for construction.
Subject to change without notice.

BY		DD/MM/YY	
DRAWN BY	ACD	28/02/23	
FINAL APPROVAL	FC	28/02/23	

LIMITED SERVICE PUMP CONTROLLER ACROSS THE LINE / 1 PHASE WITH AUTOMATIC TRANSFER SWITCH

MODEL: GPL+GLU

BUILT TO THE LATEST EDITION OF THE NFPA20 & NFPA70



DRAWING NUMBER	GPL-WS810/E
DWG REV. 0	
SHEET 2 OF 2	

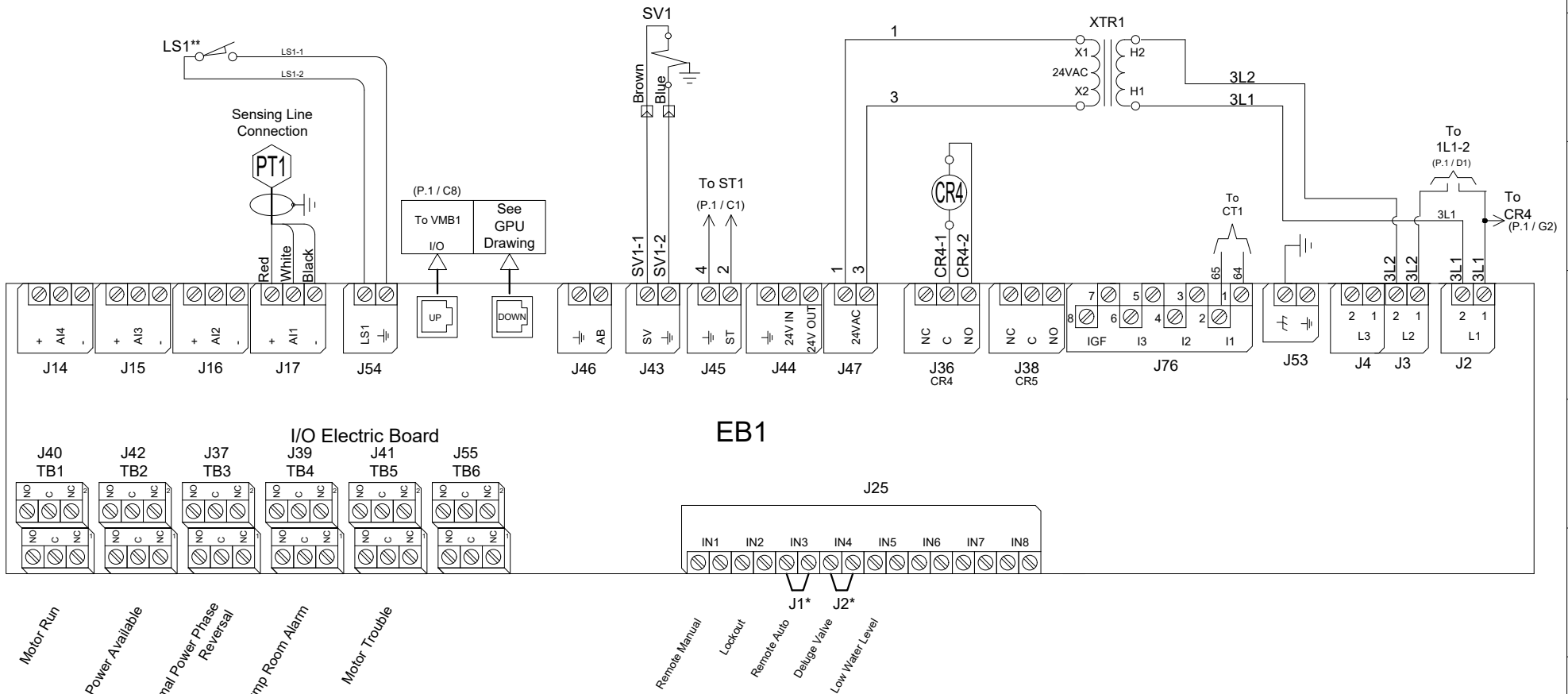

* Remove jumper to use this feature
** Contact closes when emergency start is in "ON" position



BY DD/MM/YY
 DRAWN BY ACD 28/02/23
 FINAL APPROVAL FC 28/02/23

LIMITED SERVICE PUMP CONTROLLER WITH AUTOMATIC TRANSFER SWITCH

MODEL: GLU

BUILT TO THE LATEST EDITION OF THE NFPA20 & NFPA70



DRAWING NUMBER
GLU-WS802/E
 DWG REV. 0
 SHEET 1 OF 1

© Tornatech, Inc. Not for construction.
 Subject to change without notice.

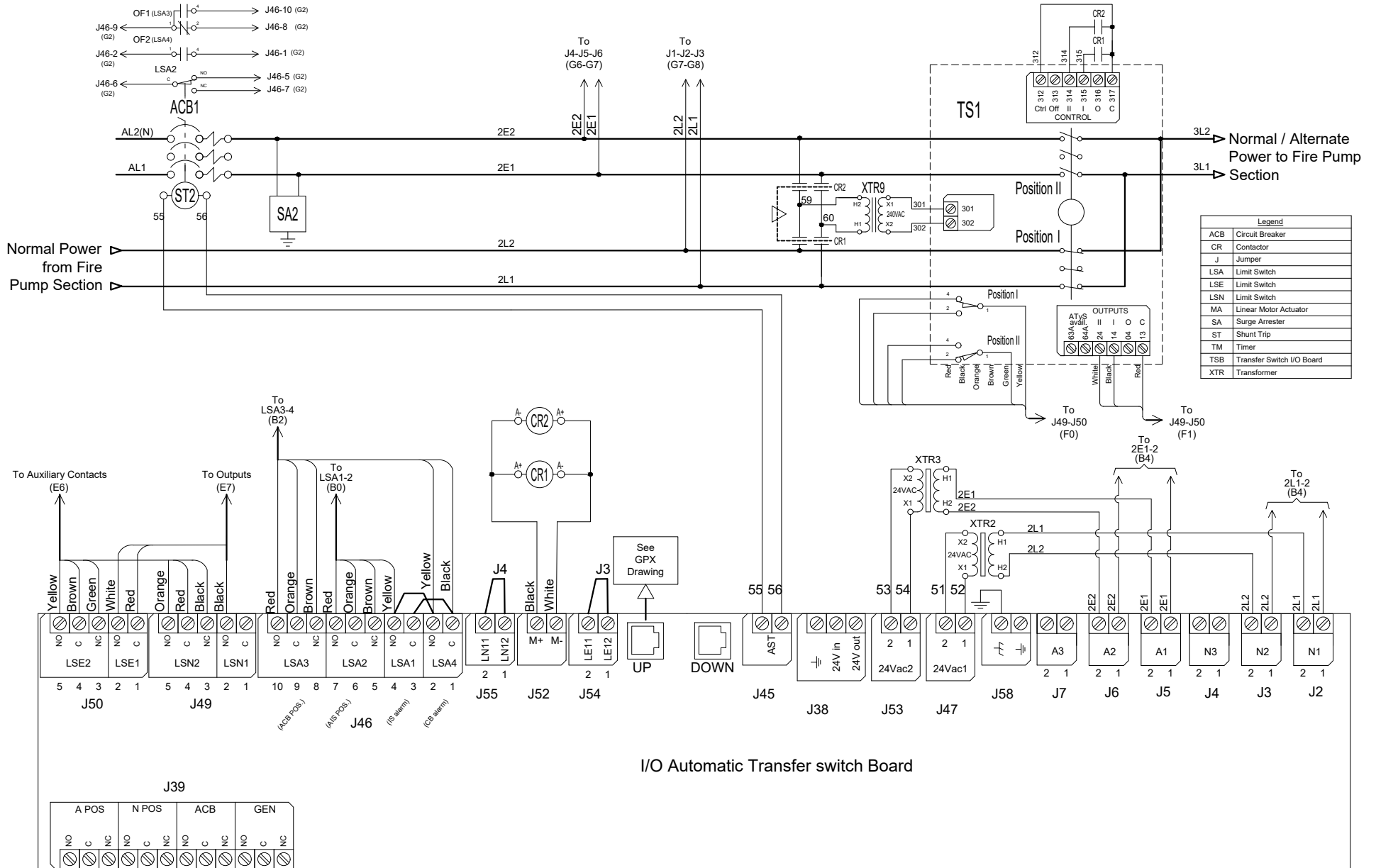

Legend	
ACB	Circuit Breaker
CR	Contactors
J	Jumper
LSA	Limit Switch
LSE	Limit Switch
LSN	Limit Switch
MA	Linear Motor Actuator
SA	Surge Arrester
ST	Shunt Trip
TM	Timer
TSB	Transfer Switch I/O Board
XTR	Transformer

I/O Automatic Transfer switch Board



BY DD/MM/YY

DRAWN BY ACD 28/02/23

FINAL APPROVAL FC 28/02/23

© Tornatech, Inc. Not for construction. Subject to change without notice.

LIMITED SERVICE PUMP CONTROLLER

MODEL: GPL

BUILT TO THE LATEST EDITION OF THE NFPA20 & NFPA70



DRAWING NUMBER
GPL-TD800/E
DWG REV. 0
SHEET 1 OF 1

Power Terminals Model : GPL 1 Phase

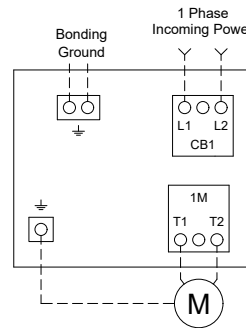

Notes:

- 1 - For proper wire sizing, refer to NFPA70 and NEC (USA) or CEC (Canada) or local code.
- 2 - Controller suitable for service entrance in USA.
- 3 - For more accurate motor connections refer to motor manufacturer or motor nameplate.
- 4 - Controller is phase sensitive. Incoming lines must be connected in ABC sequence.
- 5 - Field wiring and lug sizes are based on copper conductors only. Do not use aluminum conductors.

Circuit breaker (CB) Field Wiring according to Bending Space (AWG or MCM). TERMINALS L1 - L2

Bending Space	3" (76 mm)					
HP	1	3	5	7.5	10	15
Voltage						
120	1x (10 to 1)	1x (8 to 1)	1x (6 to 1)	1x (4 to 1)	N/A	N/A
208	N/A	1x (10 to 1)	1x (8 to 1)	1x (6 to 1)	1x (4 to 1)	1x (3 to 1)
220 to 240	N/A	1x (10 to 1)	1x (8 to 1)	1x (8 to 1)	1x (6 to 1)	1x (3 to 1)

(Use Copper Conductors Only)

Wiring Size for motor connection for Model GPL (AWG or MCM). TERMINALS T1 - T2

HP	1	3	5	7.5	10	15
Voltage						
120	1x (10 to 1)	1x (8 to 1)	1x (6 to 1)	1x (4 to 1)	N/A	N/A
208	N/A	1x (10 to 1)	1x (8 to 1)	1x (6 to 1)	1x (4 to 1)	1x (3 to 1)
220 to 240	N/A	1x (10 to 1)	1x (8 to 1)	1x (8 to 1)	1x (6 to 1)	1x (3 to 1)

(Use Copper Conductors Only)

Drawing for information only.
Manufacturer reserves the right to modify this drawing without notice.
Contact manufacturer for "As Built" drawing.



BY DD/MM/YY

DRAWN BY ACD 28/02/23

FINAL APPROVAL FC 28/02/23

© Tornatech, Inc. Not for construction. Subject to change without notice.

LIMITED SERVICE PUMP CONTROLLER WITH AUTOMATIC TRANSFER SWITCH

MODEL: GLU

BUILT TO THE LATEST EDITION OF THE NFPA20 & NFPA70



DRAWING NUMBER
GLU-TD800/E
DWG REV. 0
SHEET 1 OF 1

Power Terminals Model : GPL 1 Phase

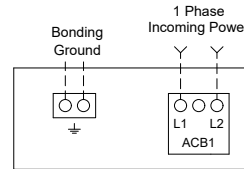

Notes:

- 1 - Controller is phase sensitive. Incoming lines must be connected in ABC sequence.
- 2 - Field wiring and lug sizes are based on copper conductors only. Do not use aluminum conductors.

Circuit breaker (CB) Field Wiring according to Bending Space (AWG or MCM). TERMINALS L1 - L2

Bending Space	3" (76 mm)					
HP	1	3	5	7.5	10	15
120	1x (10 to 1)	1x (8 to 1)	1x (6 to 1)	1x (4 to 1)	N/A	N/A
208	N/A	1x (10 to 1)	1x (8 to 1)	1x (6 to 1)	1x (4 to 1)	1x (3 to 1)
220 to 240	N/A	1x (10 to 1)	1x (8 to 1)	1x (8 to 1)	1x (6 to 1)	1x (3 to 1)

(Use Copper Conductors Only)

Remote Alarm Terminals (TSB1)

Terminals Wire Size:
24 - 12 AWG
0.5 Nm

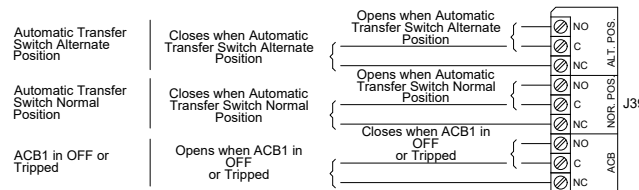

Control Terminals (TSB1)

Terminals Wire Size:
24 - 12 AWG
0.5 Nm

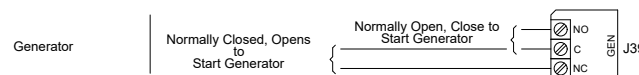

Drawing for information only. Manufacturer reserves the right to modify this drawing without notice. Contact manufacturer for "As Built" drawing.



BY DD/MM/YY

DRAWN BY ACD 28/02/23

FINAL APPROVAL FC 28/02/23

© Tornatech, Inc. Not for construction. Subject to change without notice.

LIMITED SERVICE PUMP CONTROLLER

MODEL: GPL

BUILT TO THE LATEST EDITION OF THE NFPA20 & NFPA70



DRAWING NUMBER
GPX-TD802/E
DWG REV. 0
SHEET 1 OF 1

Field Connections

Terminals Wire Size:
24 - 12 AWG
0.5 Nm

- Remote Manual
- Lockout
- Remote Auto
- Deluge Valve
- Low Water Level

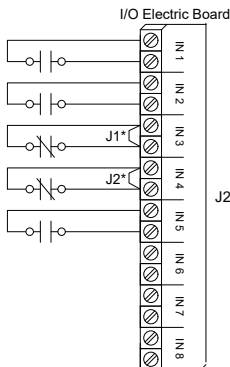

Network Connections

Terminals Wire Size:
Shielded Female Connector RJ45

Modbus TCP/IP RJ45

Located on Main Board



Alarm Contacts

Terminals Wire Size:
24 - 12 AWG
0.5 Nm

Motor Run

Power Available

Normal Power Phase Reversal

Pump Room Alarm**

Motor Trouble**

(Field Programmable)

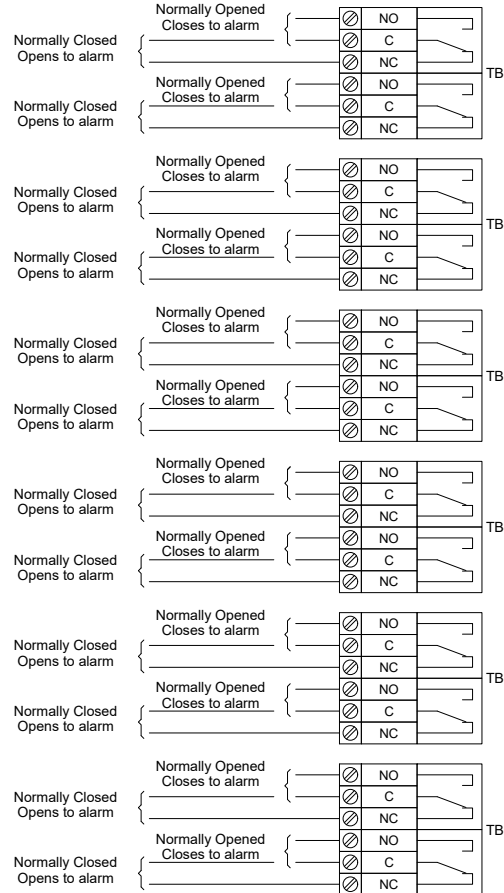

* Remove jumper to use this feature
** Re-assignable